



GUARANTEE BOOK



GUARANTEE CONDITIONS

MS więcej niż OKNA Sp. z o. o. (the Manufacturer) guarantees high quality of the Products on the principles specified in the Guarantee Book available on the Manufacturer's website www.sarnaWindows.eu, in the form applicable as of the date of sale.

As part of the guarantee, the Manufacturer declares the high quality and proper operation of the Products within the limits set by the applicable European standards; in the absence of such standards, by the standards and factory guidelines applied by the Manufacturer, which are described further in the Guarantee Book.

A. Guarantee period:

1. The guarantee period shall be from the date of sale of the Product indicated in the proof of purchase (VAT invoice):
 - a) 5 years - for sealed combined glazing units, but not exceeding 6 years from the date of production,
 - b) 5 years - for PVC joinery, and on the entire Product (i.e. profile, colour, fittings), but not exceeding 6 years from the production date,
 - c) 2 years - for additional window accessories (i.e. door self-closers, window sills, drip caps, handles, additional locks, filling panels, mosquito nets, reed relays, insulating combined glazing units ordered separately, etc.), but not exceeding 3 years from the production date.
2. Information on the date of production can be obtained from the manufacturer or the seller by providing the order number.

B. Complaints:

1. **Complaints shall be lodged directly at the place of purchase of the Products immediately upon their discovery, i.e. no later than within 14 days of their discovery, under pain of losing warranty rights.**
2. When lodging a complaint, a proof of purchase with serial numbers of Products, a description of damage, and contact details (address and phone number of the Customer) shall be submitted.
3. Claims under the guarantee may be made only upon payment of 100% of the sales price of the Product.
4. The Manufacturer's Guarantee shall not exclude, limit or suspend the rights of the Purchaser under the provisions of the warranty for defects of the goods sold.

C. Periods for handling complaints and fulfilling guarantee obligations by the Manufacturer:

1. Complaints shall be processed within 14 working days from the date of receipt of a complaint. Complaints submitted directly to the Manufacturer without reference to the Seller shall be dealt with within 21 working days. Consideration of the complaint means that on the above dates the Manufacturer shall decide whether the Customer's request is valid or whether it refuses to accept the complaint.
2. In case it is necessary to inspect the defective Product by the Manufacturer's service team, the deadline for the investigation of the complaint may be extended accordingly, but not more than another 21 working days.
3. Should a complaint be accepted, the Manufacturer shall decide on the manner of performance of obligations under the guarantee, i.e. removal of the physical defect of the Product (repair), replacement of the Product with a defect-free product or an appropriate price reduction.
4. The time limit for the fulfillment of obligations under the guarantee is 21 working days from the date of complaint acceptance. If it is not possible to fulfill the obligations under the guarantee within 21 working days for reasons beyond the control of the Manufacturer, the repair period may be extended accordingly, of which the Manufacturer shall inform the Customer.
5. Should removal of the defect of the Product depend on the weather conditions, the Manufacturer shall remove the defect if it is possible to maintain the technological parameters of the Product.



D. Exclusions:

- 1. The guarantee shall only cover manufacturing defects and/or material defects; it shall not cover:**
 - a) mechanical damage, including but not limited to: glass crack, external scratches on the glass, profile scratches, etc.,
 - b) incorrect installation and defects resulting from it,
 - c) changes, alterations or repairs to the Product made by persons other than those authorised by the Manufacturer,
 - d) damage resulting from improper operations on the Product, its improper use or insufficient maintenance. The products have basic corrosion protection and are not suitable for installation in aggressive environments (e.g. exposed to salt water mist),
 - e) damages caused by natural forces and physical events, such as water vapour condensation, frosting or freezing (in case of inadequately or insufficiently ventilated and heated rooms), cracks in the glass pane as a result of climatic factors (pressure or temperature differences), or the sound of internal muntins,
 - f) damages resulting from random events, e.g. fire, flood, lightning strike, etc,
 - g) adjustment, maintenance and cleaning of the Products, as well as replacement of fuses, batteries and other consumables that are subject to natural wear and tear during the guarantee period.
2. Colours of wood-like foil used for window and panel cladding may differ from those shown in the templet. The foil imitates natural wood with a unique structure of its rings located in different parts. Therefore, there may be slight colour variations between the profiles, which emphasizes the individual nature of the woodwork; however, this is not a basis for a complaint.
3. Door joinery, especially when it is in dark colour, exposed to direct sunlight, may be subject to an unfavorable physical phenomenon consisting in bending of the leaf/sash profiles. This bending is caused by uneven elongation of the outer and inner walls of the section due to their different surface temperature of the profiles (inside 25° C, even 65° C in the sun). The better thermal insulation of the profiles, the greater temperature difference and the more pronounced their deflection may be. The greatest deflection occurs during the hours of maximum insolation. In the following hours, the temperatures are equalized and the profiles return to their original shape. The described phenomenon is considered natural and is not the basis for a complaint.
4. Under certain conditions of observation of a window covered with decorative foil, the impression of a different shade of foil color may appear. This is caused by the intensity and angle of the sun's rays on the foil, the direction of the foil and profiles in relation to each other. We are dealing here with the optical effect of natural reflection of light. This is a situational impression that is not subject to complaint.
5. Covering an insulating glass unit with a protective film increases thermal stress in the sunlit glass. This type of uneven stress can cause the glass to crack, which is not covered by the manufacturer's warranty.

GENERAL GUIDELINES FOR INSTALLATION AND OPERATION OF WINDOWS

1. The measurement, selection and installation of windows shall be carried out by professionals, authorized dealers or MS installation teams.
2. Before installation (before dismantling the old windows) it is necessary to check whether delivered windows:
 - are consistent with the order and invoice,
 - correspond to the current demand (quantity, dimensions),
 - are intact (scratches and cracks in profiles and glass).
3. The windows shall be transported vertically and protected against damage. These shall be placed only on the bottom sill strip.
WARNING: The window - before installed - is very fragile and prone to damages.
4. Windows shall be stored in a dry and well-ventilated place, protected from sunlight and high temperatures.
5. Before installation, windows, frames and sashes shall be protected against mortar and paint (preferably with a paint film) as this type of dirt is very difficult to remove while not damaging the window.
6. See page 4 for installation instructions.
7. The windows are equipped with an internal ventilation and drainage system; the frame in the lower horizontal part is equipped with drainage holes whose task is to drain water which otherwise may get inside the window during rainfall.
ATTENTION: It is necessary to ensure that drains are unobstructed and their outlet from the outside allows free water flow onto the window sill. It is not permissible to install the window sills above the drainage holes.
8. IMMEDIATELY after installation (or completion of masonry work), the protective film and tape must be removed from the windows.
NOTE: The window MUST be cooled by flowing air. Leaving the foil on the window in high sunlight may cause its irreversible warping (hothouse effect).
9. Before using the window, the ferrules must be checked for any soiling from plaster, mortar, or dust, and cleaned if necessary.
10. The method of ferrule maintenance is specified in the manual on p. 22. The preparation for the ferrule maintenance is available in the PVC window care kit, also offered by MS.
11. In rooms with poor heating, high humidity or limited ventilation, dew can occur on the glass, which is the surface with the lowest temperature in the room. In severe frosts, dripping water can even freeze at the contact between the glass and the gasket. A solution to this problem is to improve ventilation system (additional ventilation devices, more frequent airing).
12. PVC windows must always be cleaned with a suitable preparation (available in packages for PVC windows care) or with household cleaners, excluding abrasive products (bleach) and preparations for scrubbing.
13. The seals in the windows have to be maintained twice a year by greasing preferably with sticks designed especially for this purpose.

ATTENTION:

Changes in the position of the handle may only be made after the window has been closed. During repositioning of the sash, it is necessary to press the sash against the frame.

**THROUGH ADHERING TO ABOVE-MENTIONED RULES YOU ARE GUARANTEED
MANY YEARS OF TROUBLE-FREE USE OF OUR WINDOWS**

INSTALLATION PRINCIPLES

- Before installation, it is necessary to decide on the installation method and on the type of material to be used. **The manufacturer's recommended installation methods are listed below. Details of installation for individual windows can be found later in this guarantee book.**
- Before installation, the window needs to be checked for mechanical damage and visible defects. **Damaged windows cannot be installed.** Check the correct dimensions of the window and the window openings. The gap between the window and the wall should be even and chosen according to the table below:

side length	up to 150 cm	up to 250 cm	up to 350 cm	up to 450 cm
joint width for white window incl. steel reinforcement	≥ 1 cm	≥ 1,5 cm	≥ 2 cm	≥ 2,5 cm
joint width for coloured window ncl. steel reinforcement	≥ 1,5 cm	≥ 2 cm	≥ 2,5 cm	≥ 3 cm

Modern insulation materials such as triple-function tapes do not require such large expansion joints and these can be reduced. Relevant values are given in the table below:

type of window	width or height of window/door			
	up to 150 cm	up to 250 cm	up to 350 cm	up to 450 cm
PVC white	8 mm	8 mm	10 mm	10 mm
PVC coloured	8 mm	10 mm	10 mm	12 mm

Regardless of the type of thermal insulation to be applied, the expansion joint (distance between the frame and the reveal) should not exceed 40 mm. If this distance is greater, a frame extension must be used.

- Remove the sash from the window frame, and protect the ferrule against contamination. **NOTE: The removed sash must be placed on its bottom element in order to maintain the correct position of the glass in the sash.**
- Before installing the window frame, it is necessary to glue the expansion tape depending on the structure of the window opening: for window openings without corners - to the outer edge of the frame at the top and on the sides so that the tape seals the space between the frame and the wall (fig. 7 p. 15), for window openings with corners - to the edge of the corner so that the tape seals the space between the frame and the corner and does not go beyond the limits of the window opening (fig. 8 p. 15). **NOTE: Tape widths are adapted to the width of the joint in accordance with the manufacturer's recommendations. To ensure the expansion joint tape adheres well to the window opening, the substrate should be thoroughly cleaned and, if necessary, primed.**
- The frame has to be placed in the window opening, then levelled and aligned, and the diagonals must be verified.
- Spacers for lengths exceeding 120 cm (both horizontal and vertical) are required.
- The frame must be stabilised with blocks and spacers. Necessarily, the PSK rail is to be supported. Defects caused by the deformation of the track in the PSK window are not covered by the guarantee.
- The window frame should be fixed with dowels, screws (Fig. 2a and 2b p. 6) or anchors (Fig. 3 p. 6). When using dowels in the lower part of the frame, the dowel holes must be filled with silicone to ensure sealing. The positioning of the fixings is shown in Fig. 1 on page 5.
- When installing the window kit with a connector, positioning of the fastenings on the window with the connector is identical as in case of connection to the wall. Static connectors (added to stiffen the structure) as well as external tightened stiffeners must be anchored to the floor and lintel in order to transfer the loads properly. Otherwise the structure will be deformed.
- The lower part of the window frame, outside the room, can be additionally sealed by gluing a vapour-permeable foil between the mounting strip and the window wall (Fig. 9 p. 16).



11. When installing the aluminium sill, the floor under it must be levelled (Fig. 5 p. 8). The sill must be installed with the use of expansion bolts or screws (see Fig. 4, p. 8) at a distance not exceeding 50 cm from each other (Fig. 5, p. 8).
ATTENTION: before fixing the sill to the floor, it is necessary to check if the frame with the sill has not been deformed (Fig. 6 p. 8).
12. Once the tape has completely unbonded, the remaining space between the frame and the wall should be wetted with water and filled with installation foam. In order to achieve the correct seal, the foam should also be moistened after application.
NOTE: Only low resilience foams should be used as high resilience foams may cause the frame to bow inwards. When using polyurethane foams it is essential to follow the manufacturer's recommendations.
13. Any excess should be removed once the foam has set.
14. The internal part of the joint is sealed all around using a vapour-proof membrane (Fig. 7 p. 15) or silicone (Fig. 8 p.15). In order to shape the joint correctly and reduce the use of silicone, a sponge cord can be used (Fig. 8 p. 15).
15. Covering the joint:
 - a) outside (sealing tape): it must be plastered, painted with emulsion paint or left uncovered,
 - b) inside (foam and vapour-proof foil or silicone): it must be plastered, covered with a plasterboard (fig. 8 p. 15) or a masking strip (fig. 7 p. 15).
16. The sashes should be mounted and if necessary adjusted (this operation can only be carried out by a suitably trained technical service).

NOTE: A fitter trained at MS więcej niż OKNA, having the appropriate qualifications and certificates, may change the installation method and it will not invalidate the guarantee.

ARRANGEMENT OF FIXINGS

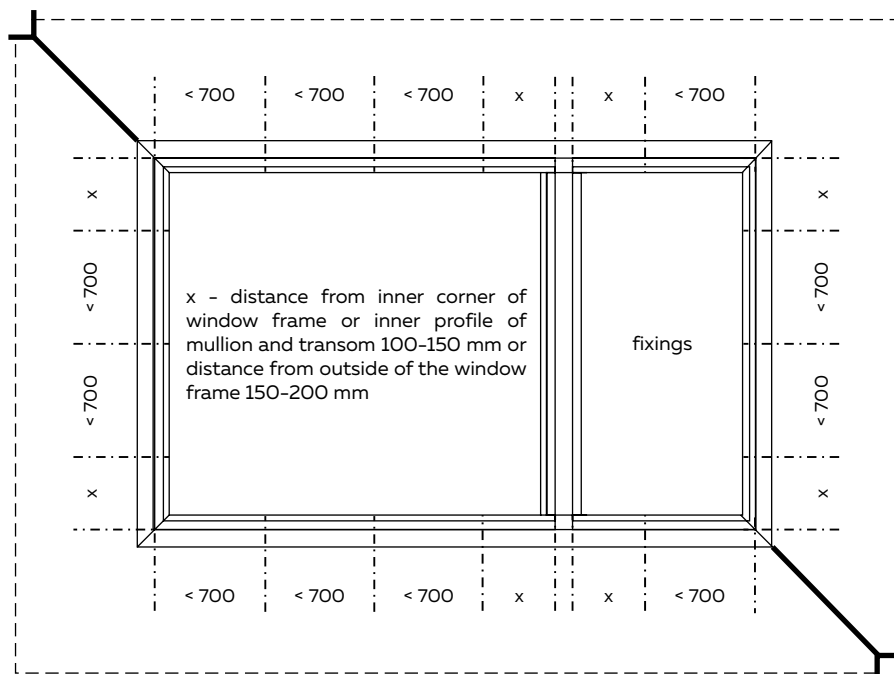

Fig. 1 Fixing PVC profiles

INSTALLATION METHODS

Installation with dowels RECOMMENDED

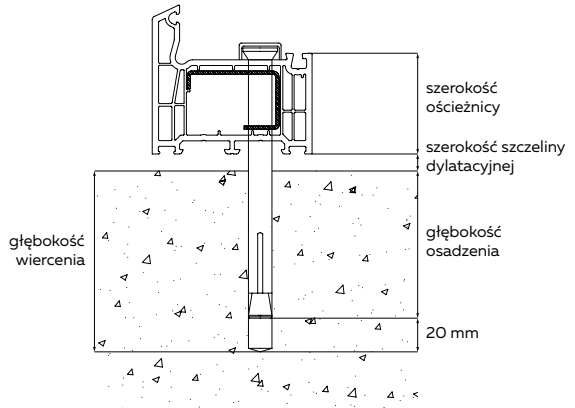

Fig. 2a

Installation with wood screw RECOMMENDED

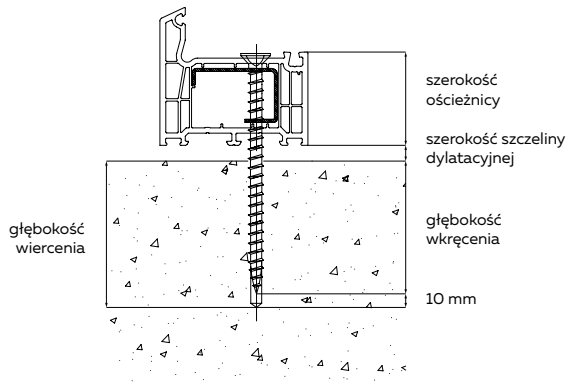

Fig. 2b

Installation with anchor bolt (ALWAYS double rawlplug) ALLOWABLE (see related table)

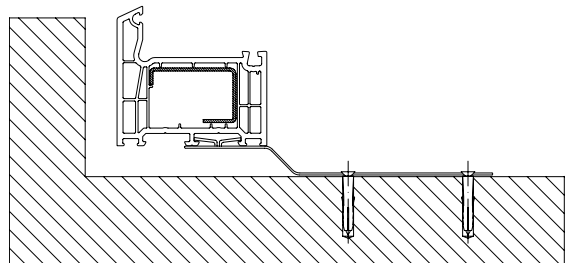

Fig. 3

Fastening with screws or dowels provides more stability and is therefore recommended for installation of doors, patios, balconies with aluminium sill, balconies with movable mullion and arched windows.

Fixing these elements with anchors may be insufficient and will be the main reason for rejecting complaints.

1. Recommended installation methods

Construction type	Anchor bolts	Screws or dowels
single- and double-sash windows with fixed mullion	Yes	Recommended
windows with movable mullion	Acceptable *	Recommended
single balcony doors or doors with fixed mullion	Yes	Recommended
balcony doors with movable mullion	Acceptable *	Recommended
balcony doors with aluminium sill	Acceptable *	Recommended
arched windows	Acceptable *	Recommended
arched balcony doors	Acceptable *	Recommended
multi-section windows with mullions or static connectors	Acceptable *	Recommended
windows with glued-in glass or wide sash	Acceptable *	Recommended
patio	Acceptable *	Recommended
doors and terraces	Acceptable *	Recommended

* installation is **ONLY** allowed with original anchor bolts including the MS logo
installation with other anchors is **NOT** allowed within these ranges

2. Correct positioning of a bolt in the window frame

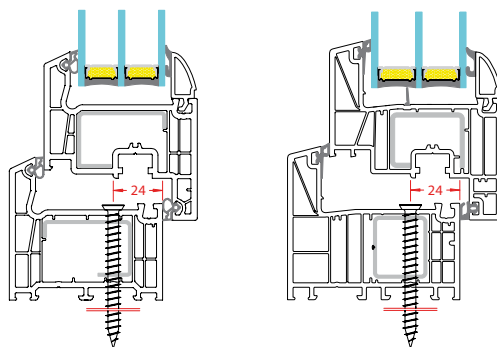

ATTENTION:

A fitter trained at MS więcej niż OKNA, having the appropriate qualifications and certificates, may change the installation method and it will not invalidate the guarantee.

3. Width of expansion gap

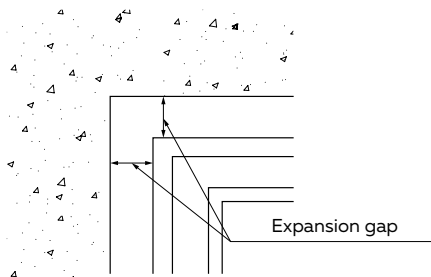

a) width of expansion gap for PU foam insulation

type of window	side length			
	up to 150 cm	up to 250 cm	up to 150 cm	up to 250 cm
white with steel reinforcement / aluminium	≥ 1 cm	≥ 1,5 cm	≥ 1 cm	≥ 1,5 cm
coloured with steel reinforcement	≥ 1,5 cm	≥ 2 cm	≥ 1,5 cm	≥ 2 cm

b) width of expansion gap for insulation with 3-function tape

type of window	width or height of window/door			
	up to 150 cm	up to 250 cm	up to 150 cm	up to 250 cm
PVC white	8 mm	8 mm	10 mm	10 mm
PVC coloured	8 mm	10 mm	10 mm	12 mm

4. Sill installation

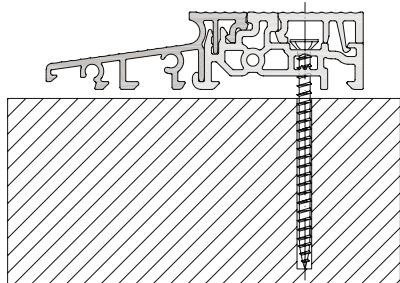

Fig. 4

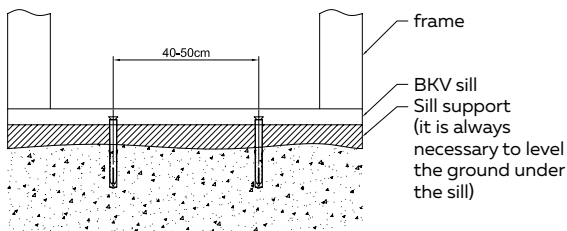
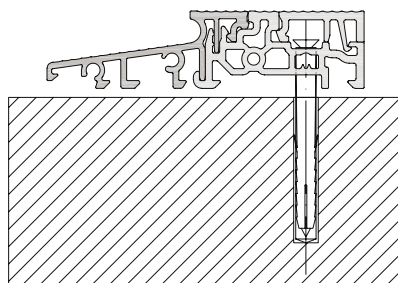

Fig. 5

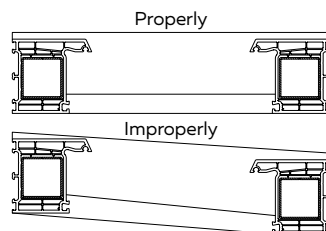
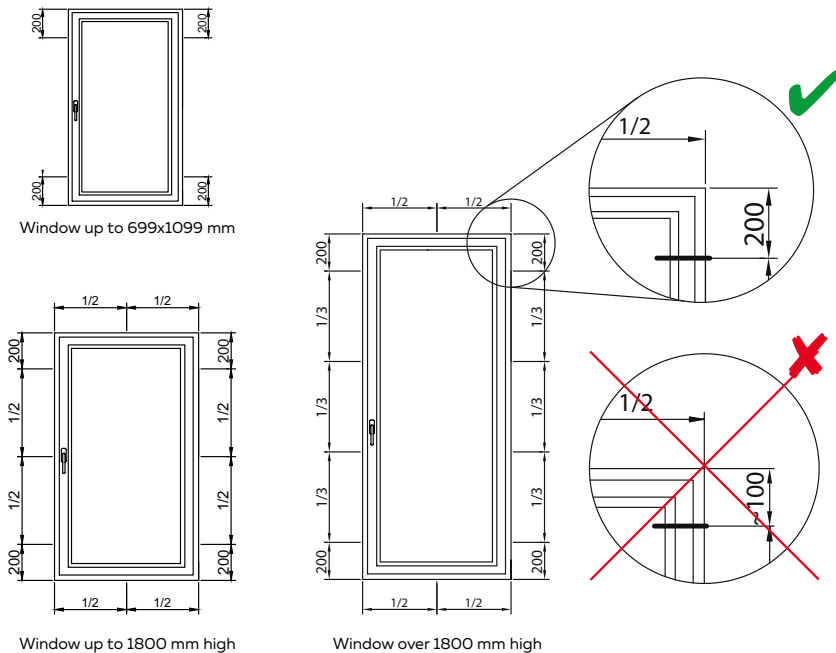

Fig. 6

DETAILED DRAWING FOR SINGLE-SASH WINDOWS (excluding balconies)

1. Arrangement of fastening elements



2. Arrangement of load-carrying blocks

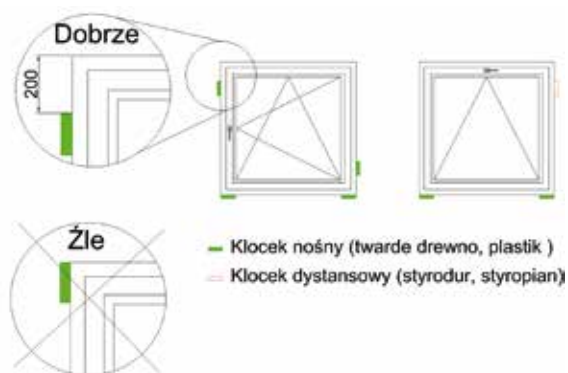

INSTALLATION OF WINDOWS INCL. FIXED MULLION (excluding balconies)

1. Arrangement of fastening elements

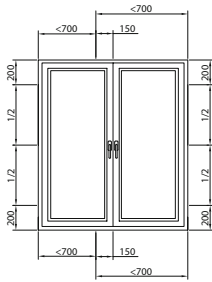

Balcony over 700mm wide

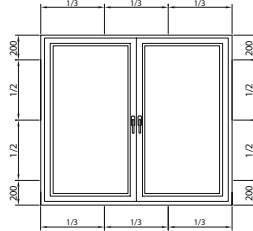

Balcony over 1400mm wide

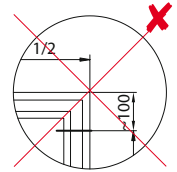
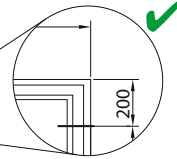
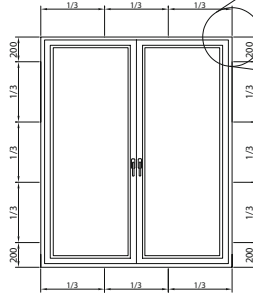
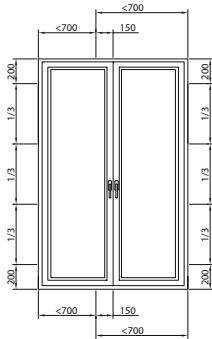

2. Arrangement of load-carrying blocks

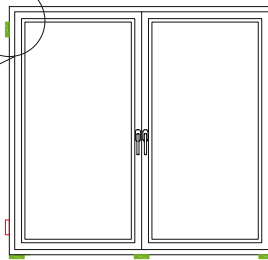
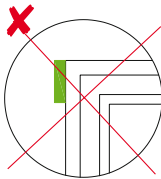
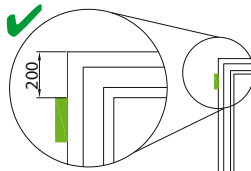

- Load-bearing block (hardwood, plastic)
- Spacer block (styrodur, polystyrene foam)

PATIO INSTALLATION

1. Arrangement of fastening elements

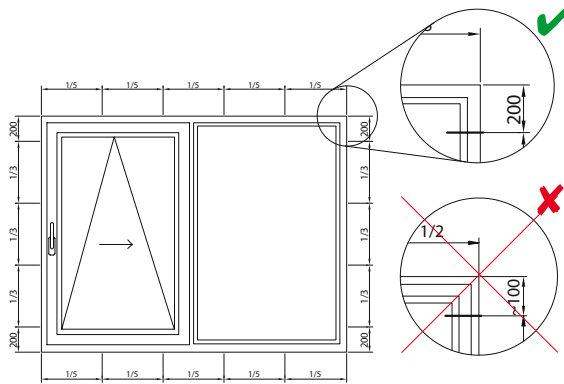

2. Arrangement of load-carrying blocks

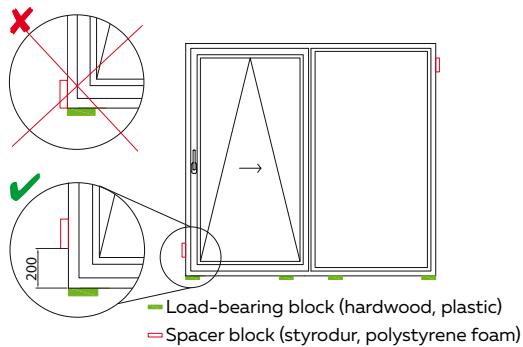

3. Rail support

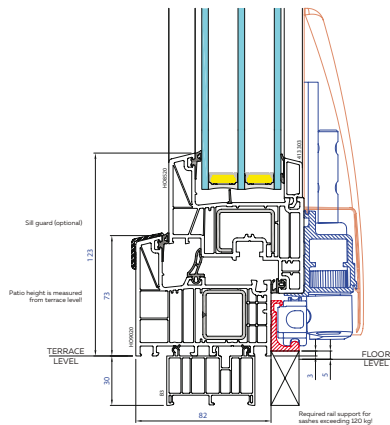

INSTALLATION OF BALCONIES WITH MOVABLE MULLION

1. Arrangement of fastening elements

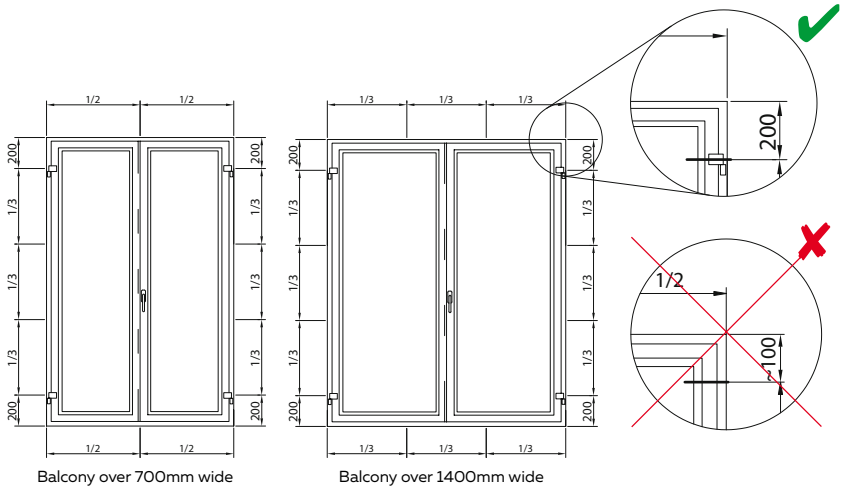

2. Arrangement of load-carrying blocks

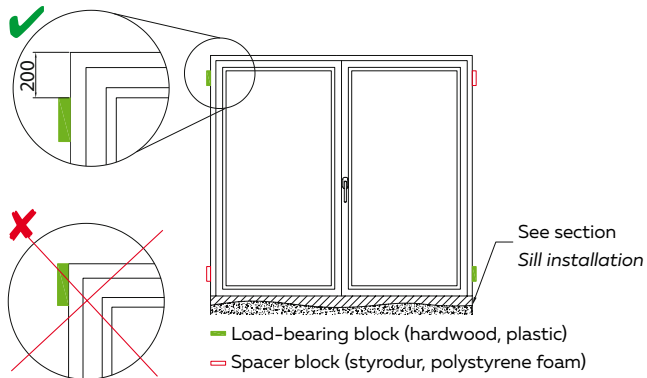

INSTALLATION OF ARCHED BALCONIES WITH MOVABLE MULLION

1. Arrangement of fastening elements

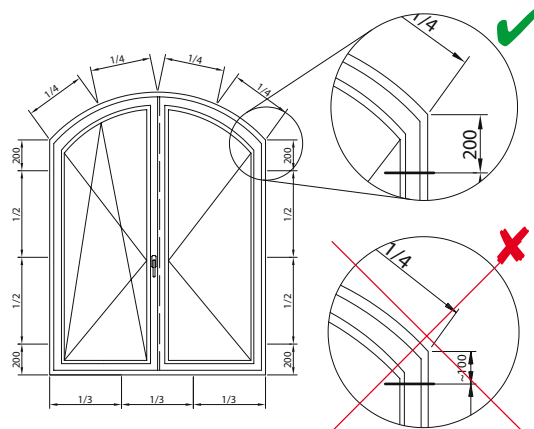

2. Arrangement of load-carrying blocks

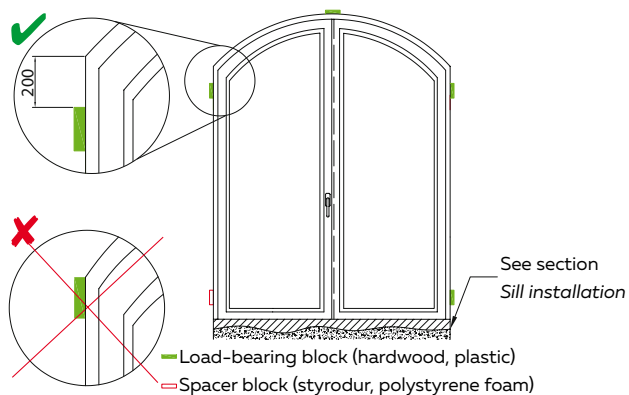

INSTALLATION OF BALCONIES, DOORS AND TERRACES

1. Arrangement of fastening elements

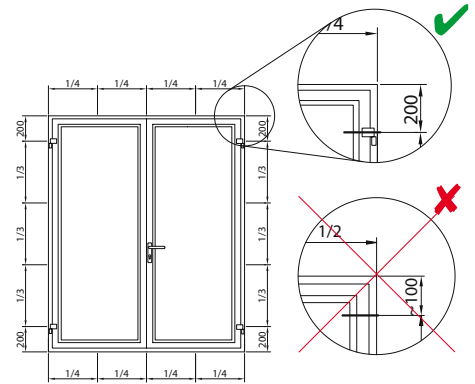
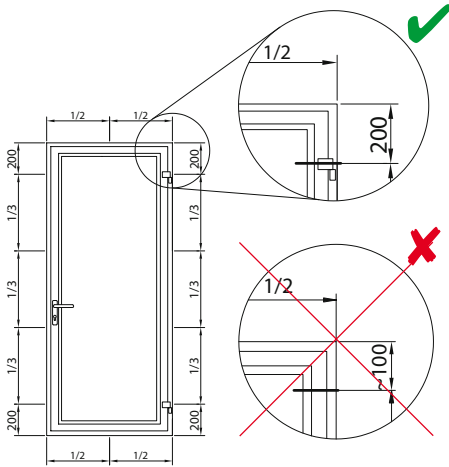

2. Arrangement of load-carrying blocks

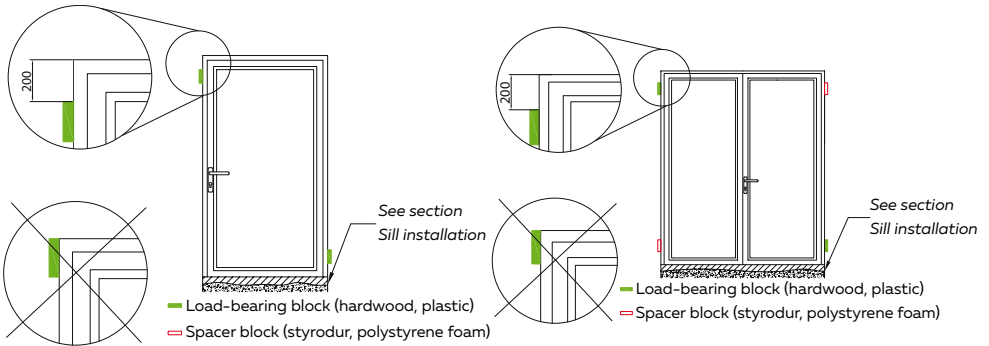

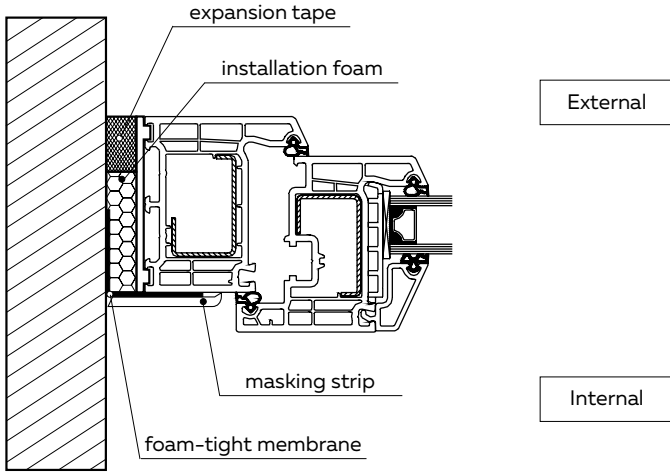

Fig. 7

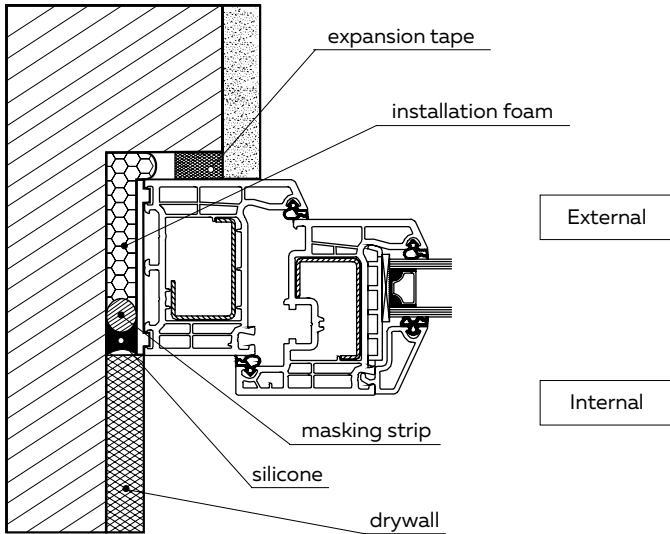

Fig. 8

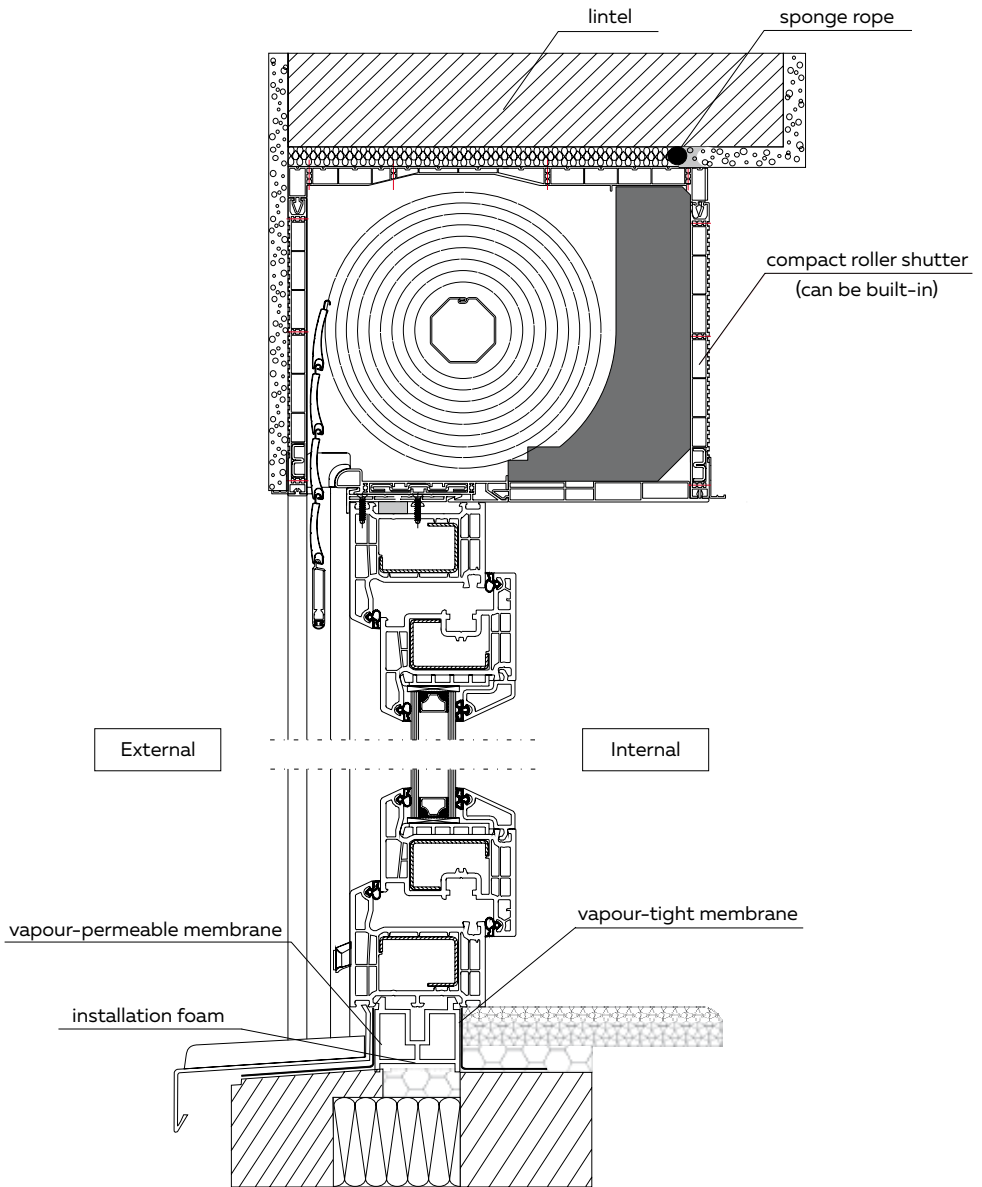
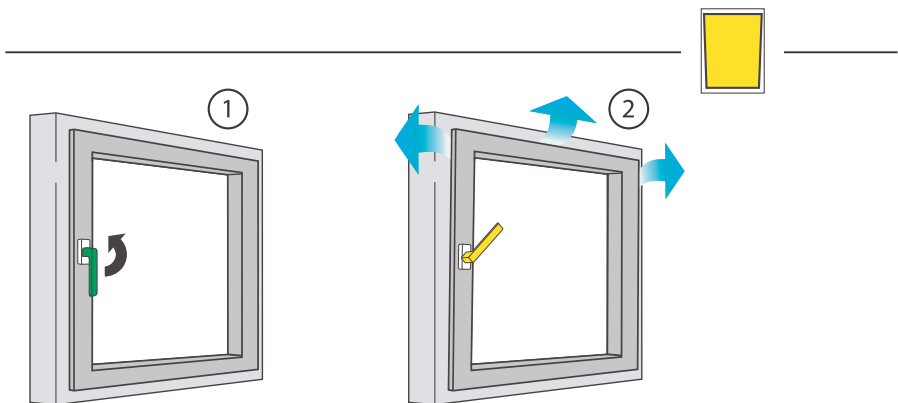
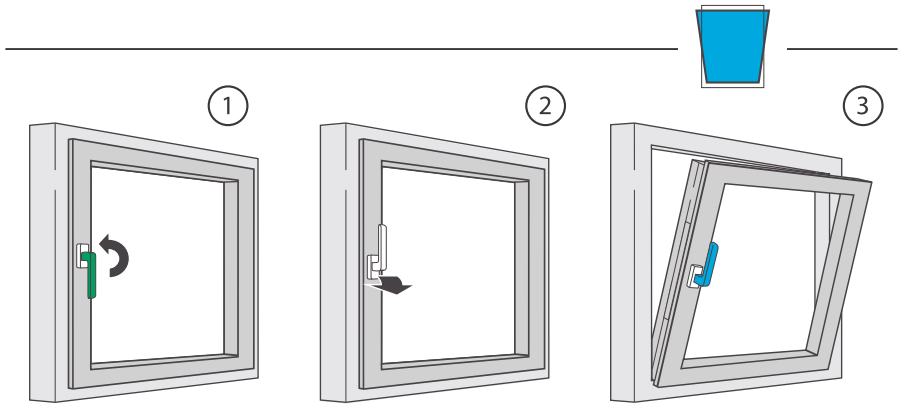
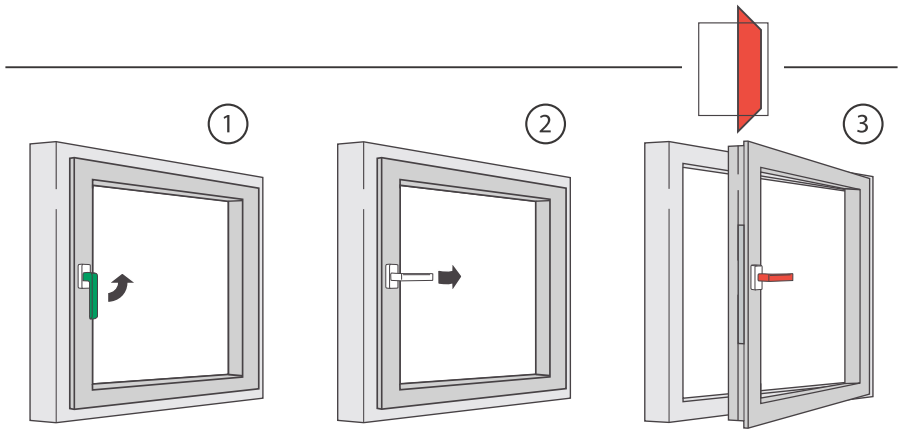
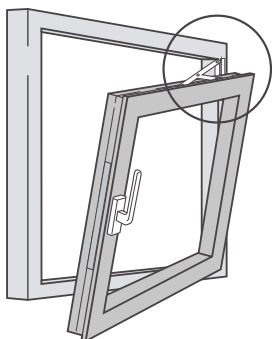
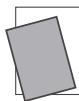

Fig. 9

OPERATION OF TILT-TURN WINDOWS



INCORRECT OPERATION - CORRECT SASH POSITIONING



1

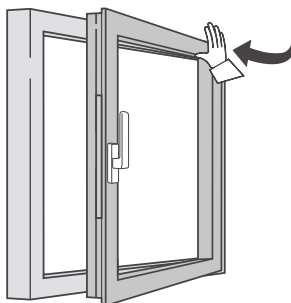

2

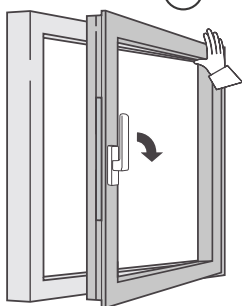

3

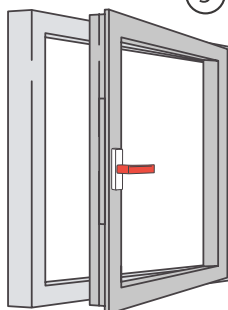

OPERATION OF TILT-TURN WINDOWS



①

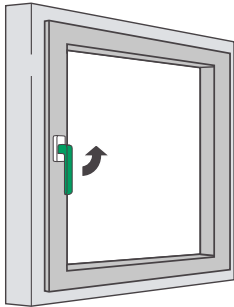

②

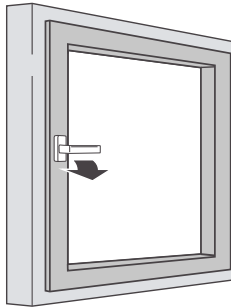

③

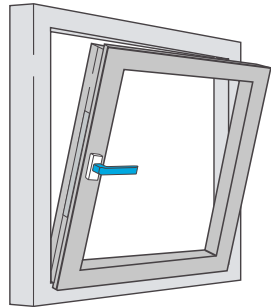

①

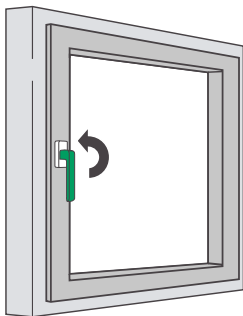

②

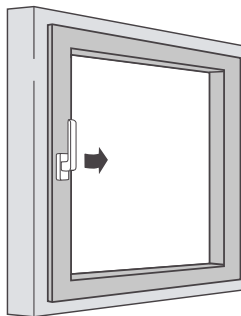

③

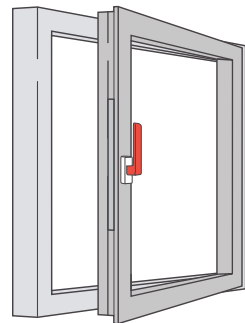

OPERATION OF TILTING WINDOWS



1

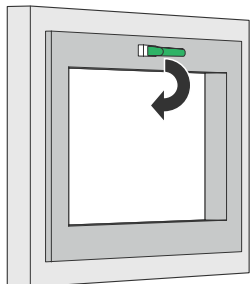

2

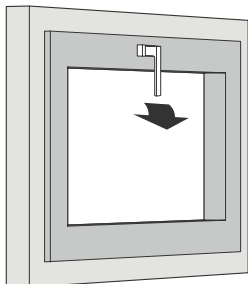

3

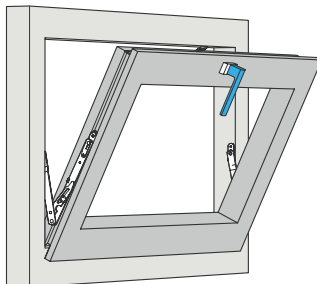

1

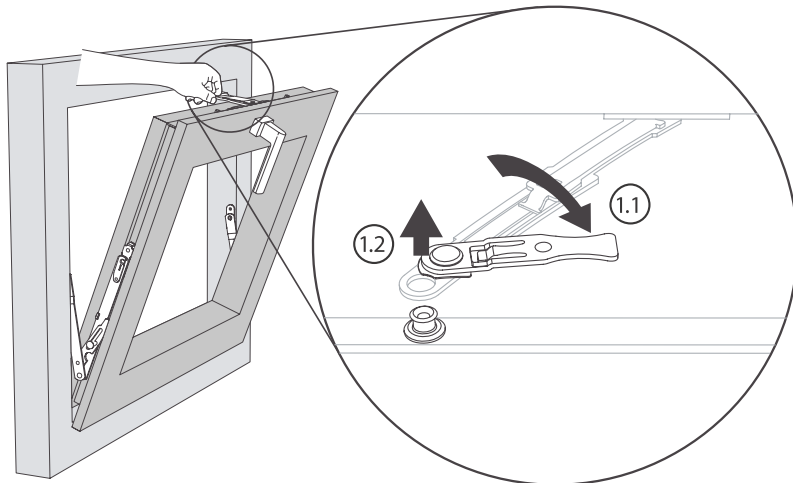

RULES FOR THE SAFE USE OF WINDOWS

- Danger of falling out of the window.



- Danger of injury (crushing) if, for example, one's hand gets between the frame and the closing sash.

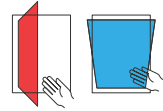

- Do not hit the open sash against the wall or the break jamb.



- Do not place any objects between the sash and the frame.

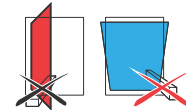

- Do not stress the sash in any way.



- Danger of injury from the open sash during strong winds.



WINDOW CARE AND MAINTENANCE

Salamander and Deceuninck profiles feature a very smooth and closed surface.

This provides protection against many types of dirt, however, any deposits should be removed regularly.

It is important to keep the surface closed. It is therefore essential to avoid:

- abrasive materials that damage the surface or chemicals such as nitro thinner, petrol, acetic acid, nail polish remover, alcohol, etc,
- cleaning products with orange or lemon fragrance,
- products containing ammonia, ammoniacal water,
- products containing sulphur (tile cleaner),
- cleaning products with sandy or abrasive properties,
- auxiliaries such as steel or scouring pads, pot cleaners.



Glass cleaners may contain ammonia or aqua ammonia which can cause surface damage.

Therefore, it is forbidden to use any products containing ammonia or aqua ammonia!

Cleaners and scouring agents containing acids must never be used; their action may damage the protective coating of the ferrule parts.

ATTENTION:

The following operations must be carried out by a competent company:

- replacement of ferrule components,
- suspension and removal of window sashes,
- adjustments on the ferrules, particularly in the area of the hinges and the nogging-piece.

To ensure that PVC windows and doors remain in good working order, the following actions must be carried out at least once a year:

- the safety-relevant ferrule components must be checked regularly. The fastening and the degree of  wear and tear are to be inspected,
- all moving parts are to be lubricated or oiled,
- for cleaning and care purposes it is essential to use products which do not affect the corrosion protection coating of the ferrule in any way.

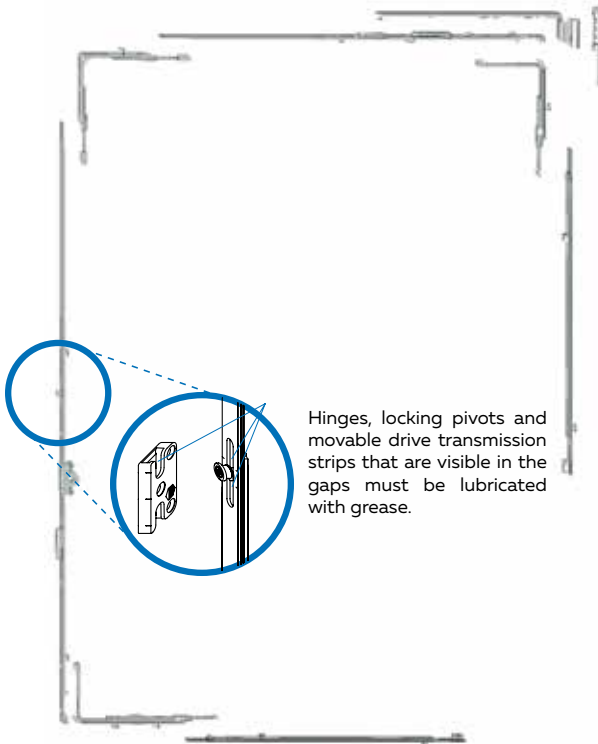
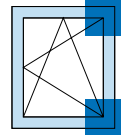
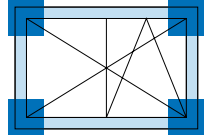

Hinges, locking pivots and movable drive transmission strips that are visible in the gaps must be lubricated with grease.

The information in this manual applies also to all types of windows which are not specified herein (e.g. double-sash windows, turned windows, tilted windows etc.).

MAINTENANCE - ASSESSMENT AND LUBRICATION

It is important to check all safety components of the ferrule (□) for fixing and possible friction.

- The upper frame hinge pin (x) must be pressed all the way in. If not, the hinge pin should be pressed all the way in.
- It is necessary to ensure that the fixing screws are not loose and that the handle is securely fastened. All loose screws must be tightened with a suitable tool.
- Caution: the screws must not be overtightened!
- Damaged ferrule parts or overtightened screws must be replaced by appropriate service staff.

All friction points are to be lubricated.

- Only greases/oils that do not contain acids or resins may be used.
- For lubrication of the ferrule's moving parts, spray lubricants, which are to be inserted into every opening of the ferrule should be applied. After lubrication, the windows must be opened/closed several times until the lubricant has distributed, and then the excess lubricant wiped off. The frame catches where the ferrule enters the fitting should be lubricated with a solid-consistency grease.

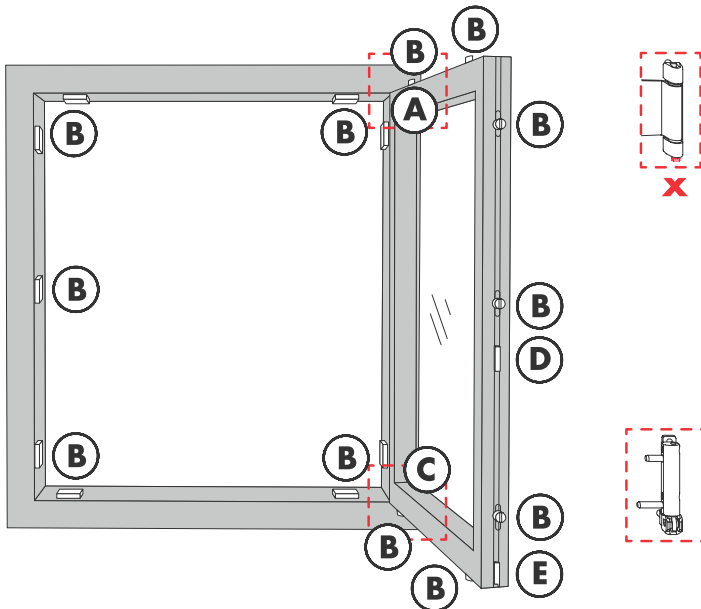

MAINTENANCE - LUBRICATION SPOTS

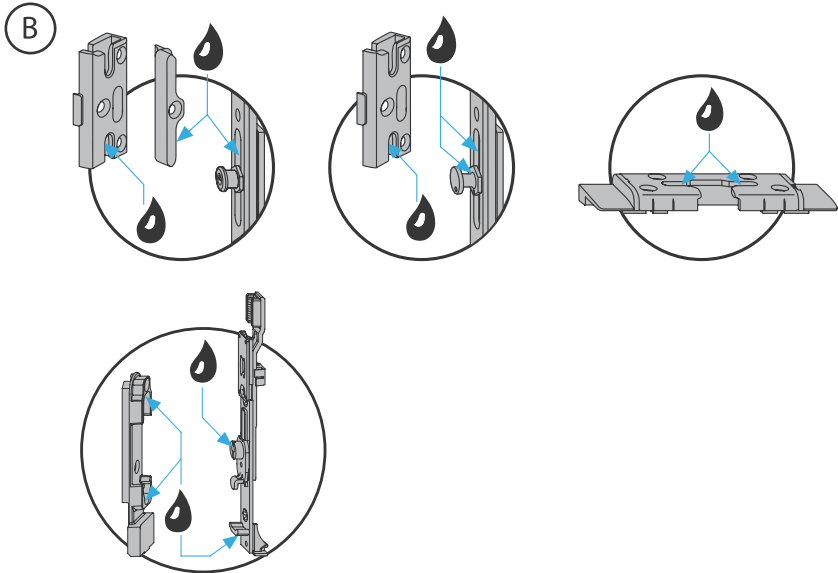
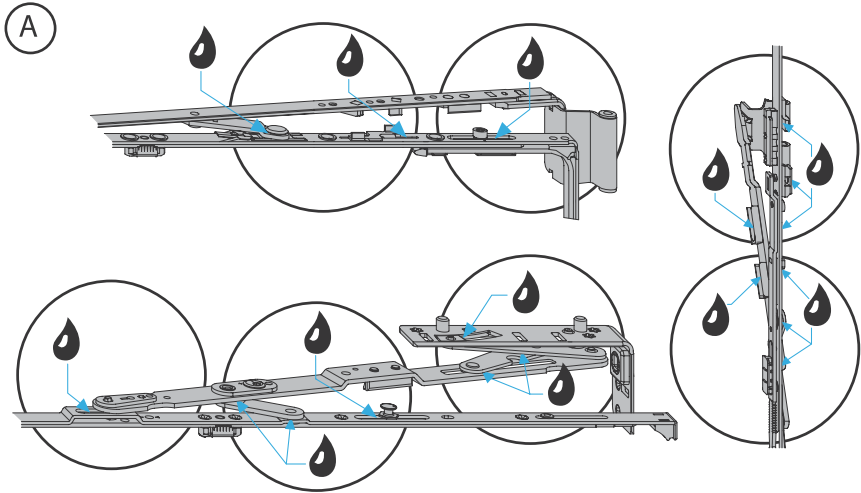

MAINTENANCE - LUBRICATION SPOTS

C

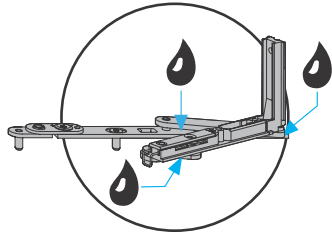
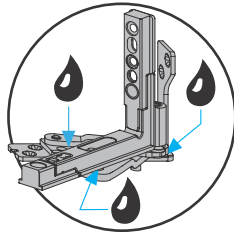
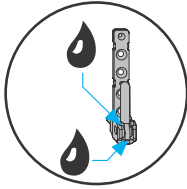

D

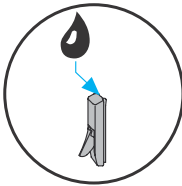

E

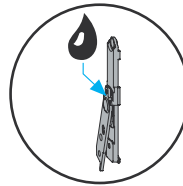

VISUAL INSPECTION ON COMBINED GLAZING UNITS

1. Conditions for inspections on glazings

The glazing shall be assessed from a minimum **3 m** distance, at an angle such that the glazing is seen in normal use, in daylight, without direct sunlight. It is necessary to look through the glass and not at the glass.

Defects not visible from such a distance are not taken into account.

Inspection time should not exceed **1 minute** for an area of 1m².

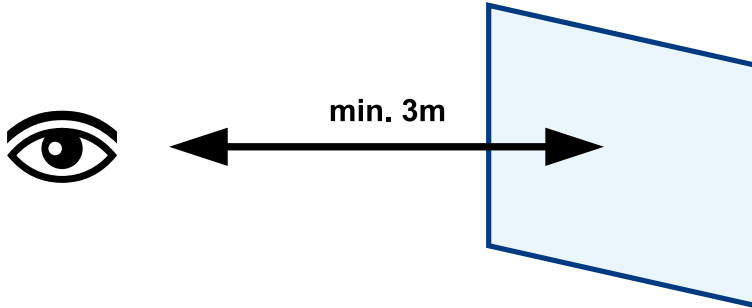

The size of the defect depends on:

- the construction of the glass (single chamber, double chamber, laminated safety glass)¹,
- its location on the glass,
- size of the glass.

Before starting to inspect the glass, its **INSPECTIONZONE** should be determined as shown in the figure below.

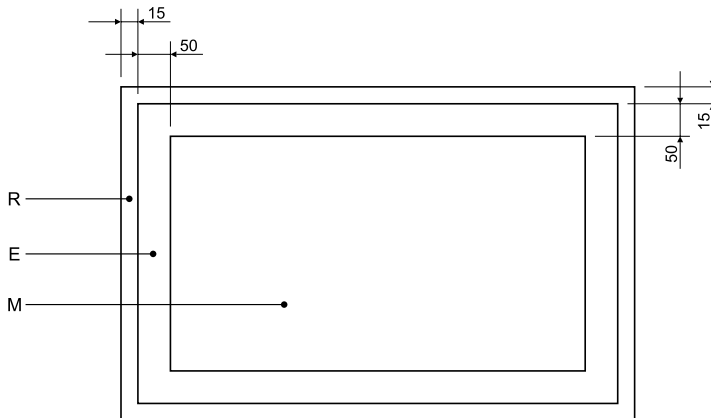

R – edge zone of 15 mm in case of panes mounted in window frames or equal to the width of the edge seal in case of panes with an exposed edge

E – perimeter zone with a width of 50 mm from the edge zone

M – main zone

¹ In case of 2-chamber glass (e.g. 4-16-4-16-4), the number of defects given in the following tables should be multiplied by 1.25. In case of 1-chamber glass including laminated safety glass, the number of defects should be multiplied by 1.5.

2. Spot flaws

Spot flaw – sferyczne lub półsferyczne zaburzenia przezroczystości widoczne podczas patrzenia przez szkło, tj. wtrącenia stałe, pęcherzyki, dziurka w powłoce, itp.

„Halo” – a locally distorted area, usually around a spot flaw.

ZONE	Flaw extent without „halo” envelope (ø in mm)	Glass size S (m ²)			
		S≤1	1<S≤2	2<S≤3	S>3
R edge area	all sizes	Allowable			
E perimeter area	ø≤1	No more than 3 pieces allowed per area ø≤20cm			
	1<ø≤3	4 pcs.	1 piece per metre of perimeter		
	ø>3	Inadmissible			
M major area	ø≤1	No more than 3 pieces allowed per area ø≤20cm			
	1<ø≤2	2 pcs.	3 pcs.	5 pcs.	5 pcs. +2 pcs./m ²
	ø>2	Inadmissible			

3. Dirt

Dirt – material present on a surface of the glass which may take the form of a stain or „patch”.

Stain – a flaw larger than a spot flaw, often irregular in shape, partly with a mottled structure, e.g. such as fingerprint.

ZONE	Type and size of flaw (ø in mm)	Glass size S (m ²)	
		S≤1	S>1
R edge area	all sizes of dirt, stains, runs	Allowable	
E perimeter area	Dirt ø≤1	Allowable	
	Dirt 1<ø≤3	4 pcs.	1 piece per metre of perimeter
	Stain, run ø≤17	1 pcs.	
	Dirt ø>3 and stains ø>17	1 pcs.	
M major area	Dirt ø≤1	Max 3 pcs. per area ø≤20cm	
	Dirt 1<ø≤3	Max 3 pcs. per area ø≤20cm	
	Dirt ø>3 and stains ø>17	Inadmissible	

4. Linear irregularities

Linear irregularities – flaws, which may be on or in the glass, in the form of marks or scuffs, e.g. a scratch.

Cluster – a group, an accumulation of very small flaws that seem to be a stain.

Thin capillary cracks are acceptable, provided they do not occur in a cluster.

ZONE	Length of single scratch / linear irregularity	Total length of scratches / linear irregularities
R edge area	Allowable	
E perimeter area	≤30 mm	≤90 mm
M major area	≤15 mm	≤45 mm

5. Rectilinearity tolerances for spacer frames

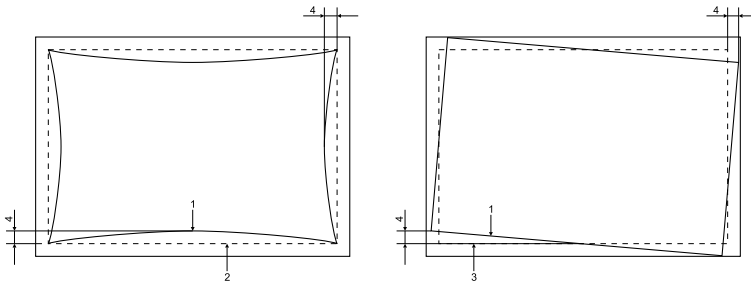

- 1 – spacer frame
- 2 – theoretical shape of a spacer frame
- 3 – theoretical location of the spacer frame
- 4 – deflection

In case of 1-chamber glazing, the straightness tolerance of the spacer frame is 4 mm for lengths up to 3.5 m and 6 mm for the longer sides.

In case of 2-chamber glass, the permissible frame deviation in relation to the parallel straight edge of the glass or other frame (frame shift) is 3 mm for edge lengths up to 2.5 m. For longer edge lengths, the permissible deviation is 6 mm.

6. Foreign matters on the spacer frame

Occurrence of single, non-accumulated foreign bodies on the distance frame, e.g. residues of desiccant, glass particles, frame, muntin bars, etc., which may have got inside the combined glazing unit during production, is acceptable. These effects are not subject to complaints.

The sealing compound of the unit may protrude beyond the edge seal and be visible in the inter-pane space.

7. Allowable defects on the pane edge

- external shallow edge damage or chipping that does not affect the strength of the glass and does not extend beyond the width of the edge seal,
- internal chipping without loose spalling which has been filled by a sealant.

8. Other acceptable visual effects

- fogging, condensation on the glass surface,
- imprints of suction cups, stickers, rollers visible on damp (fogged) glass,
- different coloured lines, so called Brewster's reflected rays,
- colour change of glazing bars due to coatings or own colour of glass,
- 1 mm gaps in the joint of the spacer frame,
- gaps in the connection of the internal muntins.

9. Disadvantages of toughened glass (based on PRESSGLASS Company Internal Standard)

It is important to bear in mind that there may be additional phenomena in toughened glass resulting from the heat treatment. These phenomena do not mean that toughened glass is defective.

These include:

- a) the rainbow effect - caused by the anisotropy of strength and the formation of a specific stress field generated during toughening. It causes a double refraction of light in the glass which becomes visible under polarised light - the stress fields are visible as coloured areas called „polarised fields” or „leopard spots”. „Polarised fields” are visible on the glass when observed from a small angle also in daylight (this phenomenon is well visible on toughened car windows),
- b) „RolerWaves” - these occur during the toughening of glass in horizontal furnaces and are surface deformations caused by the hot glass (temperature close to the softening point) coming into contact with the furnace rollers. This creates deviations in the straightness of the glass. These deviations are usually visible in reflected light. When placing orders for glass panes to be used for glazing façades, it is recommended that the customer take into account the „Roler Waves” phenomenon and specify the direction of application of the glass panes to the hardening furnace (directional hardening),

Straight line tempel

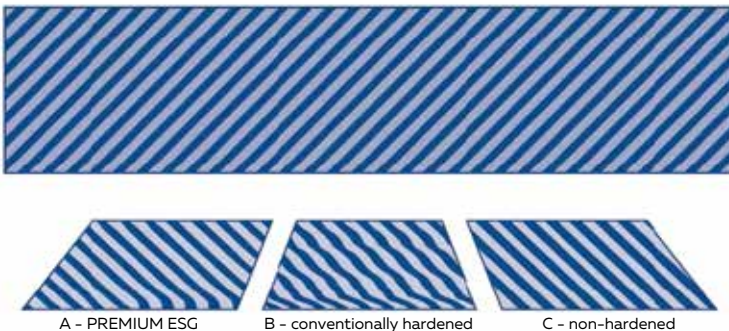

- c) „roller reflection” - with glass that is thicker than 8 mm and with thinner but larger glass, small imprint marks may become visible („roller reflection”).

The Toughened Glass Internal Standard of the toughened glass supplier will apply to the assessment of toughened glass.

10. Evaluation of the internal glazing bars

The internal glazing bar should be assessed from a distance of 3 m from the angle at which it is visible in normal use, in daylight, without direct sunlight. Defects not visible from this distance are not taken into account. The surface A of the bars is subject to assessment, while the side surface H is not subject to assessment (see drawing).

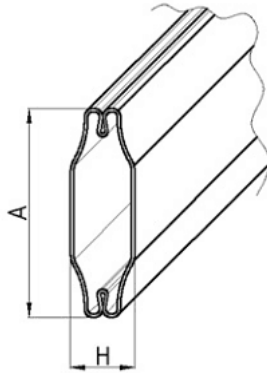

GUIDELINES FOR ASSESSMENT OF BUILT-IN PVC WINDOWS

1. Functionality check

Deformations, including changes in the shape and dimensions of windows (bulging, hourglass) should not significantly impair their performance, i.e. functionality. They must not cause damage to the window elements, i.e. pulling out and damaging the fittings, corrosion of the fittings, damaging the seals.

- 1.1 Opening and closing of the sashes should be done without jamming and stopping.
- 1.2 The opened sash should not close or open under its own weight.
- 1.3 When closed, the sash should adhere evenly to the frame, ensuring tightness between those elements.

2. Deformation check

Measurement must be carried out on closed sashes.

Lp.	Deformation	Permissible deviation
2.1	Deviation from vertical and horizontal planes for panel lengths up to 3000 mm	1,5 mm/m
2.2	Difference in length between frame and sash diagonals for element lengths up to 2 m	2 mm
2.3	Difference in length of diagonal frames and sashes for element length exceeding 2 m	3 mm
2.4	Frame deformations	1,5 mm/m
2.5	Local flatness deviation	0,3 mm

3. Measurement of the actuating and closing force of the ferrule

(operating forces when turning the handle): $F \leq 10 \text{ Nm}$

4. Quality control

The assessment of the appearance of a built-in PVC-U window should be made **from a distance of 2 m at a right angle**.

External elements are assessed in diffuse daylight and internal elements in light appropriate to the use of the room.

A closed window is subject to qualitative assessment.

No.	Element to be assessed	Requirement
4.1	Profile surface	Smooth, free of discontinuities and non-removable impurities
4.2	Colour of unglued profile	Uniform white
4.3	Veneer	There must be no creases, abrasions, blisters or inclusions in any area visible when the window is closed. Edges in areas not visible when the window is closed may protrude from the profile as much as possible so that they do not collect dirt or make cleaning difficult
4.4	Appearance of 45° corner joints	No discontinuities or inclusions
4.5	Appearance of HFL corner joints	Straight, flat, free from dents or inclusions. Openings visible from the top and bottom of the sash are not to be assessed, as they are not visible when the window is examined according to the guidelines described in section 4. The profile outer walls are movable, which does not constitute a flaw
4.6	Positioning the profiles against each other	Misalignment of the visible profile surfaces: · up to 0.6 mm for up to 80 mm deep profiles · 1 mm for over 80 mm deep profiles
4.7	Evaluation of filling (glass, panel with glass)	According to the guidelines related to the assessment of insulating combined glazing units
4.8	Evaluation of additional accessories, such as handles, grips	Varnished surface without paint chips. Individual discolourations, capillary scratches and spot inclusions are permissible provided they are not visually striking

5. Corrections made by a qualified technician.

A qualified technician can remove minor surface damage, deformation and tarnishing with the appropriate tools and cleaning agents. Such professional repairs do not affect the durability of the profiles. The criteria given above apply when assessing the results of the repair.

Reference documents:

1. Technical conditions for the execution and acceptance of construction works. Installation of windows and doors. Building Research Institute, Warsaw 2016.
2. PN-EN 12608-1:2016 Unplasticized poly(vinyl chloride) (PVC-U) profiles for the fabrication of windows and doors. Classification, requirements and test methods. Part 1: Uncoated PVC-U sections with bright-coloured surfaces.
3. Quality guidance. Windows, exterior doors and façade elements. Plattform Fenster und Fensterfassaden. Wien.
4. PN-EN 14351-1+A2:2016 Windows and doors. Product standard, performance characteristics. Part 1: Windows and external doors that have no fire resistance and/or smoke control characteristics.